

# HANTS Control Limited



**HANTS**®

**HANTS CONTROL LIMITED**

No.42,Jialing Street. Cianjhen District, Kaoshiung City, Taiwan

Tel: +886-7-3311060 Fax: +886-7-3310100

E-mail: [sales@hants.com.tw](mailto:sales@hants.com.tw)

[www.hants.com.tw](http://www.hants.com.tw)

# Valvula de Alivio/Seguridad Serie 901

## Informacion General

### Clase 300



#### Caracteristica Principal y Especificacion

Modelo Hants – 901

|                                  |         |                           |
|----------------------------------|---------|---------------------------|
| Presion Nominal                  | PN      | Clase 300                 |
| Resistencia del Cuerpo           | Ps(Mpa) | 7.5                       |
| Presion de Ajuste                | Pk(Mpa) | 1.6~5                     |
| Presion de Sello                 | Pm(Mpa) | 90% Pk                    |
| Presion de Re-Asiento            | Ph(Mpa) | $\geq 90\% Pk$            |
| Presion de Alivio                | Pp(Mpa) | $\leq 1.03 Pk$            |
| Altura de Elevacion              | H(mm)   | $\geq 1/4 d0$             |
| Rango de temperature de Servicio |         | $\leq 300^{\circ}C$       |
| Tipo de Servicio                 |         | Aire, Gas, Vapor, Liquido |

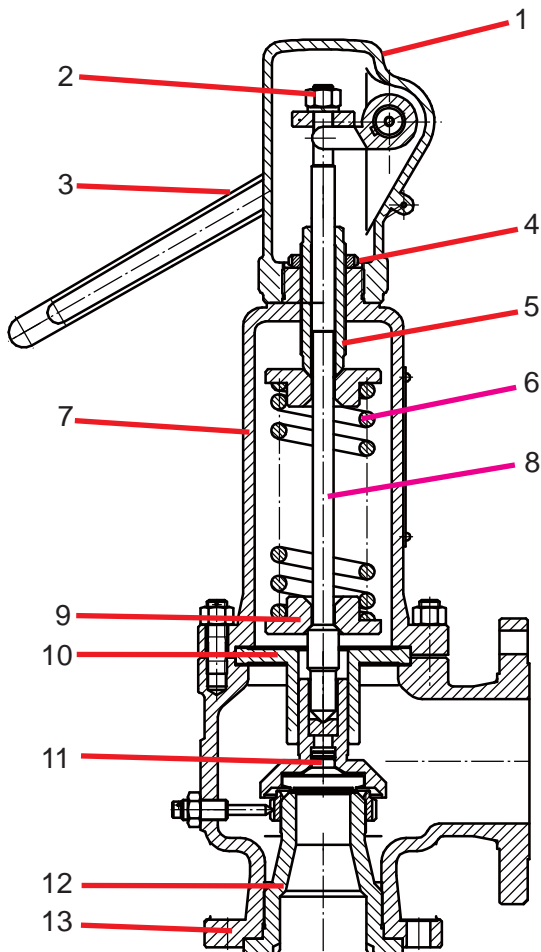

#### Materiales

| No. | Parte                  | Material      |
|-----|------------------------|---------------|
| 1   | Tapa                   | WCB A216      |
| 2   | Tuerca de Bloqueo      | Acero         |
| 3   | Palanca                | WCB A216      |
| 4   | Tuerca Tornillo Ajuste | Acero         |
| 5   | Tornillo de Ajuste     | Acero         |
| 6   | Resorte                | Inconel X-750 |
| 7   | Cuerpo Intermedio      | WCB A216      |
| 8   | Vastago                | SUS 420       |
| 9   | Platillos Resorte      | Acero         |
| 10  | Guia                   | SS 316        |
| 11  | Disco                  | SS 316        |
| 12  | Asiento                | SS 316        |
| 13  | Cuerpo Principal       | WCB A216      |

**HANTS®**

**HANTS Control Limited**

**No.40, Jialing Street, Kaoshiung, Taiwan**

# Valvula de Alivio/Seguridad Serie 901

## Dimension de valvula

### Clase 300

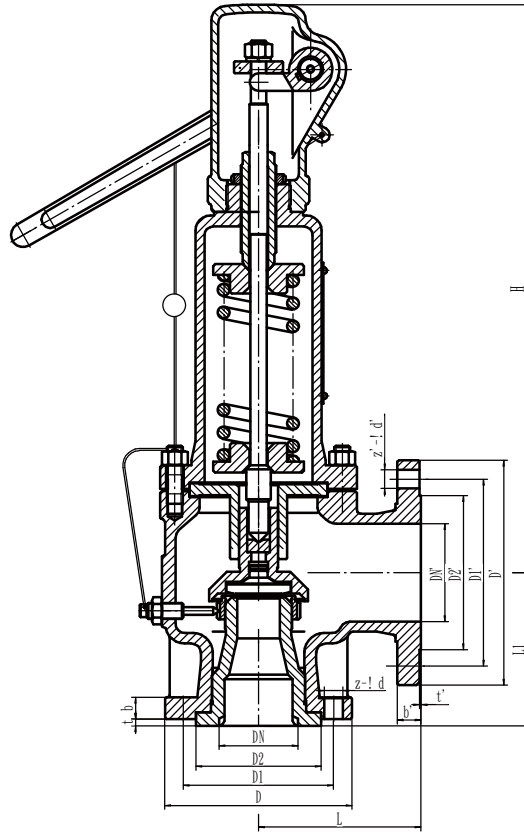

| Diámetro Nominal | Diámetro(mm) |       |     |    |    |       |     |     |       |     |    |     |       |     |     |     |
|------------------|--------------|-------|-----|----|----|-------|-----|-----|-------|-----|----|-----|-------|-----|-----|-----|
|                  | D            | D1    | D2  | b  | t  | z-Ød  | DN  | D'  | D1'   | D2' | b' | t'  | z-Ød' | L   | L1  | H   |
| 1/2" x 3/4"      | 95           | 66.5  | 35  | 15 | 5  | 4-15  | 20  | 98  | 70    | 43  | 14 | 1.6 | 4-15  | 90  | 90  | 320 |
| 3/4" x 1"        | 117          | 82.5  | 43  | 16 | 5  | 4-19  | 25  | 108 | 79.5  | 51  | 15 | 1.6 | 4-15  | 96  | 92  | 330 |
| 1 x 1 1/2"       | 124          | 89    | 51  | 18 | 5  | 4-19  | 40  | 127 | 98.5  | 73  | 18 | 1.6 | 4-15  | 115 | 105 | 340 |
| 1" x 2"          | 124          | 89    | 51  | 18 | 5  | 4-19  | 50  | 152 | 120.5 | 92  | 18 | 1.6 | 4-19  | 115 | 105 | 340 |
| 1 1/2" x 2"      | 156          | 114.5 | 73  | 20 | 5  | 4-22  | 50  | 152 | 120.5 | 92  | 18 | 1.6 | 4-19  | 121 | 124 | 360 |
| 1 1/2" x 2 1/2"  | 156          | 114.5 | 73  | 20 | 5  | 4-22  | 65  | 178 | 139.5 | 105 | 20 | 1.6 | 4-19  | 121 | 124 | 380 |
| 1 1/2" x 3"      | 156          | 114.5 | 73  | 20 | 5  | 4-22  | 80  | 190 | 152.5 | 127 | 22 | 1.6 | 4-19  | 124 | 130 | 380 |
| 2" x 2 21/2"     | 165          | 127   | 91  | 22 | 5  | 8-19  | 65  | 178 | 139.5 | 105 | 20 | 1.6 | 4-19  | 124 | 130 | 390 |
| 2" x 3"          | 165          | 127   | 91  | 22 | 5  | 8-19  | 80  | 190 | 152.5 | 127 | 22 | 1.6 | 4-19  | 124 | 130 | 390 |
| 2 1/2" x 4"      | 190          | 149   | 105 | 24 | 5  | 8-22  | 100 | 229 | 190.5 | 157 | 24 | 1.6 | 8-19  | 143 | 137 | 390 |
| 3" x 4"          | 210          | 168.5 | 127 | 28 | 5  | 8-22  | 100 | 229 | 190.5 | 157 | 24 | 1.6 | 8-19  | 162 | 156 | 460 |
| 4" x 6"          | 254          | 200   | 157 | 32 | 10 | 8-22  | 150 | 279 | 241.5 | 216 | 26 | 1.6 | 8-22  | 210 | 197 | 540 |
| 6" x 8"          | 318          | 270   | 216 | 38 | 10 | 12-22 | 200 | 343 | 298.5 | 270 | 29 | 1.6 | 8-22  | 241 | 240 | 780 |
| 8" x 10"         | 381          | 330   | 270 | 42 | 10 | 12-25 | 250 | 406 | 362   | 324 | 31 | 1.6 | 12-25 | 279 | 276 | 820 |
| 10" x 12"        | 445          | 387.5 | 324 | 46 | 10 | 16-29 | 350 | 533 | 476   | 413 | 35 | 1.6 | 12-28 | 350 | 330 | 890 |

**HANTS®**

**HANTS Control Limited**  
**No.40, Jialing Street, Kaoshiung, Taiwan**