

## Technical Data

- \*Size: DN50(1.5")-DN300(12")
- \*Nominal Pressure: PN10/PN16
- \*Working Temperature: -45°C--+200°C
- \*Suitable Mediums: Fresh water, Sewage,
- \*Sea water, Air, Oils, Acids, Alkalis, Salts, etc

## Operation

- \*Generally, DN50(1.5")-DN300(12") with lever operator.
- \*All of DN50(1.5")-DN300(12") also can be with electric operator & pneumatic according to the clients' requirements.

## Standard

- \*Design & Manufacture acc.to API 609, MSS SP-67 BS5155, BS EN593..
- \*Face to Face acc.to DIN3202, API609, MSS SP-67, BS5155, BS EN558, ISO5752.
- \*Top Flange acc.to ISO5211.
- \*Pressure test acc.to API598, BS EN12266-1, DIN3230, BS5155.
- \*Side Flange acc.to DIN2501, ANSI125/150, AS2129, BS4504, BS10D&E, JIS10K.

## Part Name & Its Code

No.	Part Name	No.	Part Name
1	Body	9	Washer
2	Seat	10	Half washer
3	Disc	11	Spring circlip
4	Stem	12	Lever
5,7,8	Bushing	13	Gear box
6	"O" Ring		

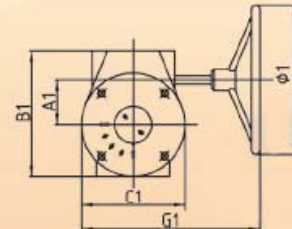
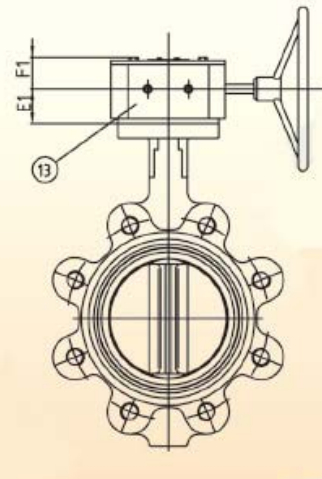
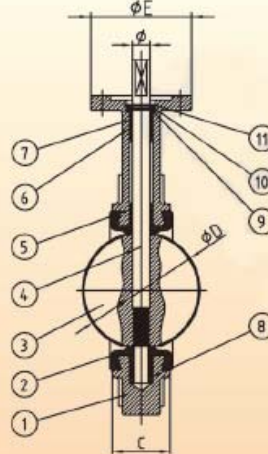
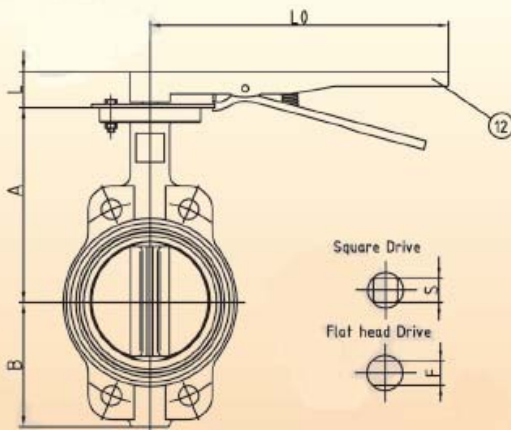

SIZE	A	B	C	D	L	E	Top flange	φ	F	S	L0	A1	B1	C1	E1	F1	G1	φ1
DN50	140	80	42.3	56	32	90	F07	12.6	10	9	266.7	45	128	105	36	28	226	150
DN65	152	89	45.8	67.87	32	90	F07	12.6	10	9	266.7	45	128	105	36	28	226	150
DN80	159	95	45.8	80.5	32	90	F07	12.6	10	9	266.7	45	128	105	36	28	226	150
DN100	178	114	52	106.3	32	90	F07	15.77	12	11	266.7	45	128	105	36	28	226	150
DN125	191	127	55	131.2	32	90	F07	18.92	14	14	266.7	45	128	105	36	28	226	150
DN150	204	139	55	153.5	32	90	F07	18.92	14	14	266.7	45	128	105	36	28	226	150
DN200	238	175	61	205.08	45	125	F10	22.1	17	17	359	63	179	152	46	34	313	300
DN250	270	203	67.2	255.4	45	125	F10	28.45	22	22	359	63	179	152	46	34	313	300
DN300	315	242	77	306.6	45	125	F10	31.8	24	22	505	78	200	164	46	36	307	300

Note:

"In order to keep the policy of 'continual improvement of product', we are entitled to keep improvement in design, material quality, size and specifications etc. Forgive for no further notice.



## Part Name & Material

- \*Body C./D./carbon steel/stainless steel/Al-Bronze
- \*Disc :Nickel-plated DI/ stainless steel/Al-Bronze/nickel copper alloy/DI+epoxy coated/PTFE coated/nylon coated/rubber coated
- \*Seat: rubber(refer to the sheet of seat materials)
- \*Stem: stainless steel
- \*Bushing: glass backed PTFE/luberized bronze
- \*\*"O" Ring: NBR/EPDM/viton
- \*Washer: stainless steel/carbon steel
- \*Half washer: bearing steel
- \*Spring circlip: stainless steel/ carbon steel
- \*Lever: malleable cast iron/aluminum/carbon steel
- \*Gear box: cast Iron/ aluminum