

NPS	Main dimension (mm)						Weight (KG)	Torque N*M without Safety factor
	L	Ød	ØS	A	H	W		
1/2"	92	Ø14	Ø21.8	9.6	65	135	1.85	20
3/4"	111	Ø19	Ø27.1	12.7	78	165	2.70	25
1"	127	Ø25	Ø33.8	12.7	90	220	4.40	35
1 1/4"	140	Ø32	Ø42.6	12.7	93	220	6.35	45
1 1/2"	152	Ø38	Ø48.7	12.7	103	255	8.72	60
2"	178	Ø49	Ø61.1	15.9	115	305	10.90	80

*Safety factor of 1.3 is recommended

1.	Nondestructive testing		
1.1	Pressure test	API 598	Yes
1.2	Chemical composition certification	Mandatory	Yes
1.3	Penetrant test	All Body Surface	Yes
1.4	Magnetic particle testing	All Body Surface	Yes

NO.	PART NAME	MATERIAL	REMARKS
1	BODY	A182 F316	
2	STUD BOLTS	A193 GR.B8M	
3	NUT	A194 GR.8M	
4	BODY GASKET	SS316+GRAPHITE	
5	BONNET	A182 F316	
6	BALL	A182 F316	
7	SEAT RING	DEVLON	
8	STEM	A182 F316	
9	THRUST WASHER	RPTFE	
10	STEM "O" RING	VITON	
11	PACKING	GRAPHITE	
12	GLAND	A276 SS316	
13	POSITIONING PIN	STAINLESS STEEL	
14	POSITIONING PLATE	STAINLESS STEEL	
15	LEVER	SS201+PLASTIC	
16	STEM NUT	SS304	
17	LOCKING DEVICE	SS304	

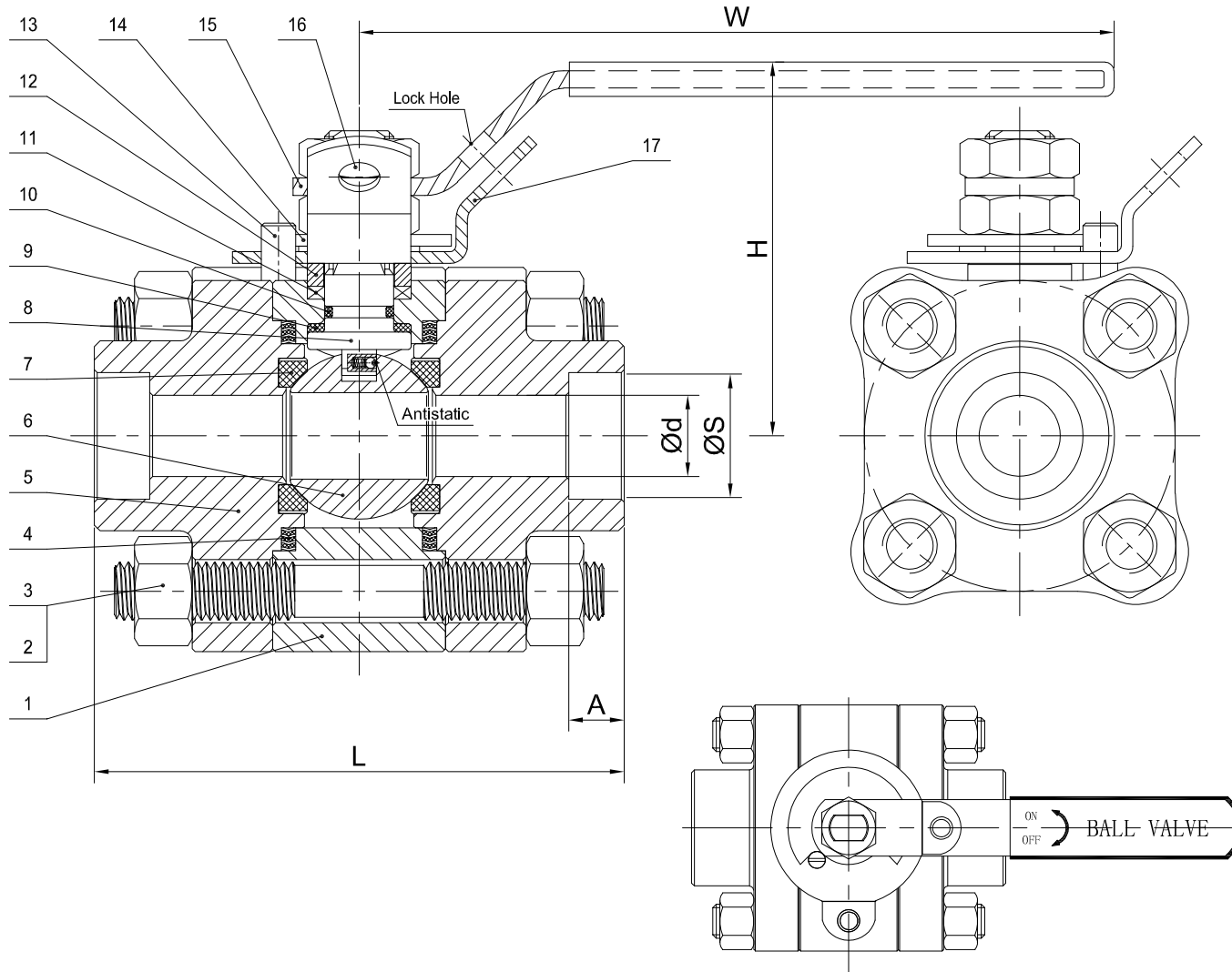

SPECIFICATION REQUIRED	ASME B16.34
TYPE of VALVE	FLOATING TYPE
VALVE OPERATING	LEVER OP.
VALVE PRESSURE CLASS	3000 PSI
END CONNECTION TYPE	SW
END to END DIMENSION	MANUFACTURER STANDARD
SOCKET-WELDING END	ASME B16.11
TEST	API 598
FIRE SAFE TEST	API 607
APPLICABLE TEMPERATURE	-20°C ~ +120°C
APPLICABLE MEDIA	WATER.OIL.GAS.STEAM. etc

TEST PRESSURE	PRESSURE	SHELL:	30.80 MPa
		SEAT:	22.60 MPa
	PRESSURE	SEAT:	0.60 MPa
Date	REV.No.	DESIGNED	
DWG.No.		REVIEWED	
CLIENT		APPROVED	

3PC FORGED STEEL FLOATING TYPE BALL VALVE
NPS 1/2"~2" CLASS 3000PSI F316/F316/DEVLON SW

PTV[®]
Solutions