

Omega™ Double Effect Air Vent

Din Series for drinking water

Designed to protect pipelines from air lock and vacuum collapse, the Omega™ Series Combination Air Release and Vacuum Breaker Valve eliminates air and prevents vacuum formations in pipelines. A large venting orifice and large float clearances freely exhaust or admits air during pipeline filling or draining. Omega is the most effective solution to maintain pipeline efficiency and protection from adverse pressure conditions.

Features:

- A) Charge and discharge air capacity in one model
- B) Maintenance can be easily performed from the top without removing the air valve from the pipeline
- C) Simple, Effective, Patented Design
- D) Corrosion resistant materials of construction, coating suitable for highly aggressive environments (Blue Epoxy paint)
- E) Engineered For Lasting Service
- F) Advanced and compact design with simple mechanisms
- G) Available with Flanges and Thread NPT Ends
- H) Smooth cage outside of the float, keep floating ball moving in specified guide rail
- I) Floating ball made in stainless steel A276 SS316 secure a long lasting life
- J) Suitable for most common environments: drinking water, clean water, irrigation, and non-corrosive chemical pipelines.

Performance Standard

1. Size range: Flange DN 50~DN200
Threaded: NPS 1"~2"
2. Pressure Ratings: PN16/PN25/PN40
3. Working temperature: -29°~ +120°C.
4. Suitable Medium: Drinking Water and non-corrosive chemicals.
5. Body Material: ASTM A216 WCB
6. Trim Material: SS316
7. Seat: NBR Buna
8. Blue Epoxy Paint

Technical Data

1. Design & Manufacture standard as to: ASME B31.3
ASME B16.34
1. Height dimension (H) standard as to: MFR-STD
3. Flange dimension conforms as to: BS EN 1092-1
4. Testing And Inspection as to: API 598
5. Pressure-temperature conforms as to: ASME B16.34
6. Anti Corrosion as per NACE MR-0175(2002) requirement



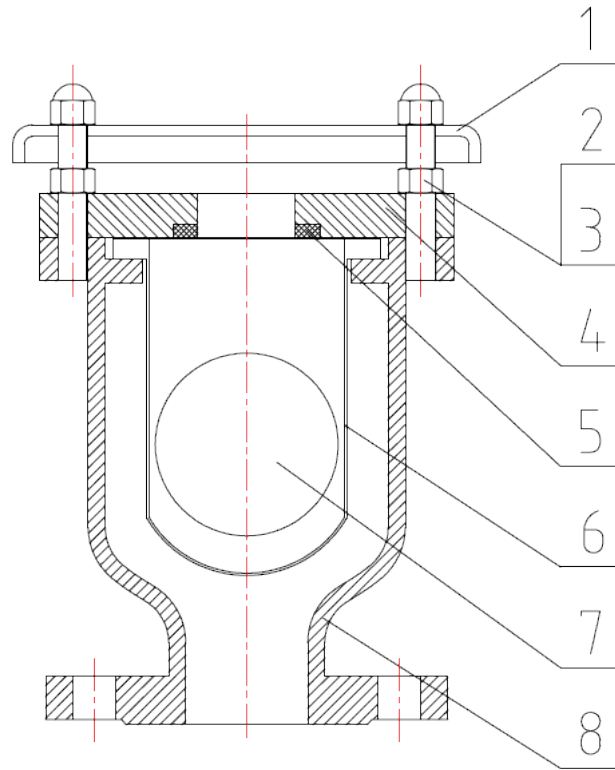

Part List:

Omega Double Effect Air Vent Flanged Din PN16/25/40:

No.	Part Name	Material	Standard
1.	Cap	F304	ASTM A182
2.	Bolt	B7 (Galvanized)	ASTM A193
3.	Nut	2H (Galvanized)	ASTM A194
4.	Cover	C.S.	ASTM A105
5.	Seat	NBR	BNS-D00040
6.	Protective Bushing	C.S.	ASTM A216 WCB
7.	Floating Ball	SS316	ASTM A276
8.	Body	C.S.	ASTM A216 WCB

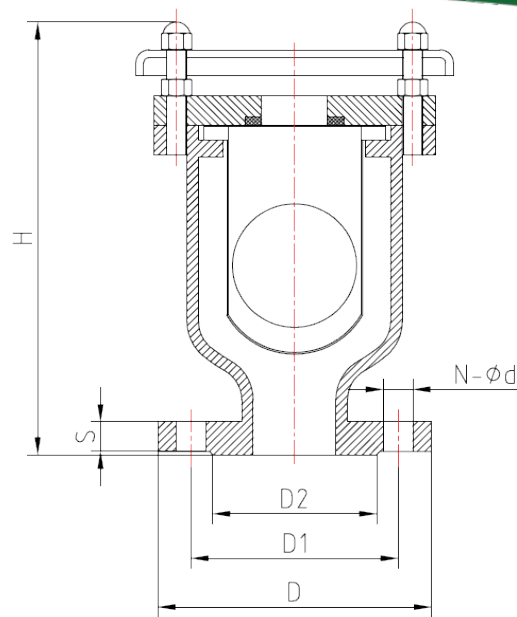

Omega Dimension of Flange Din PN16/25/40:

DIN PN16

Flange dimension standard conforms as to: BS EN 1092

NPS	H	D	D1	D2	S	N-Φ	f	Weight Kg
2"	260	165	125	102	20	4-Φ18	3	12.5
2 1/2"	270	185	145	122	20	8-Φ18	3	17.5
3"	270	200	160	138	20	8-Φ18	3	18.5
4"	300	220	180	158	22	8-Φ18	3	24
6"	370	285	240	212	24	8-Φ22	3	36.5
8"	420	340	295	268	26	12-Φ22	3	54

DIN PN25

Flange dimension standard conforms as to: BS EN 1092

NPS	H	D	D1	D2	S	N-Φ	f	Weight Kg
2"	260	165	125	102	20	4-Φ18	3	12.5
2 1/2"	270	185	145	122	20	8-Φ18	3	17.5
3"	270	200	160	138	20	8-Φ18	3	18.5
4"	300	220	180	158	22	8-Φ18	3	24
6"	370	285	240	212	24	8-Φ22	3	36.5
8"	420	340	295	268	26	12-Φ22	3	54

DIN PN40

Flange dimension standard conforms as to: BS EN 1092

NPS	H	D	D1	D2	S	N-Φ	f	Weight Kg
2"	260	165	125	102	20	4-Φ18	3	12.5
2 1/2"	270	185	145	122	22	8-Φ18	3	17.5
3"	270	200	160	138	24	8-Φ18	3	18.5
4"	300	220	180	158	26	8-Φ18	3	24
6"	370	285	240	212	30	8-Φ22	3	36.5
8"	420	340	295	268	32	12-Φ22	3	54

Omega Double Effect Air Vent Thread NPT End: Part List of Thread NPT End:

No	Name	Material	Standard
1.	Cap	F304	ASTM A182
2.	Bolt	B8M	ASTM A193
3.	Nut	8M	ASTM A194
4.	Cover	F316L	ASTM A182
5.	Seat Protective	Viton	USA DuPont
6.	Protective Bushing	SS316L	ASTM A276
7.	Floating Ball	SS316L	ASTM A276
8.	Body	CF3M	ASTM A351

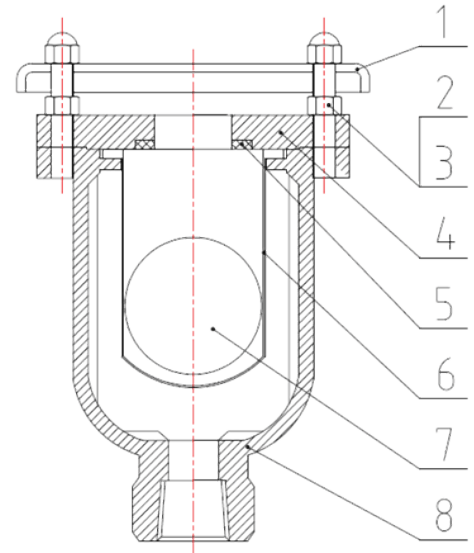

Omega Dimension of Thread Standard as to ASME B1.20.1

Class 150LB / 300LB NPT Threaded End

NPS	NPT	H	Φ	Weight Kg	
				150LB	300LB
1"	1"	210	135	5	5.6
1 1/4"	1 1/4"	210	135	5.5	6
1 1/2"	1 1/2"	215	150	7	7.5
2"	2"	215	150	8	9

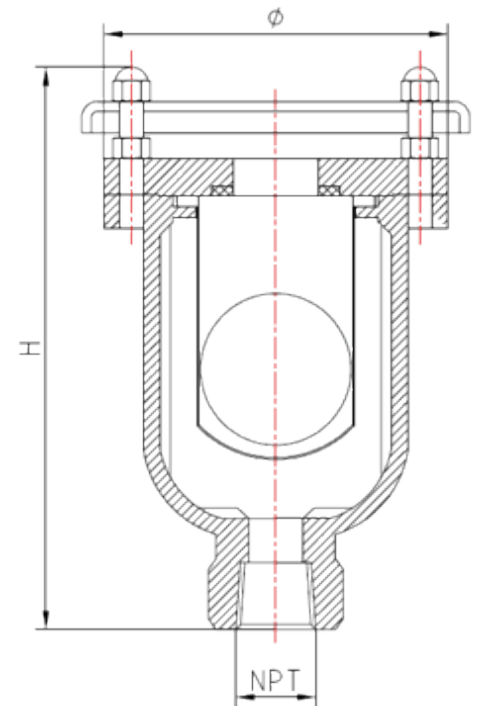

ORDERING CODE:

Example: OMEGA CS-23-21-200

Model: OMEGA AIR VENT CAST STEEL SERIES CLASS 150
Standard A216 WCB Body Red Epoxy
SS316 CF8M Interior and floating ball
NBR Buna seat
Flanged End RF
Rating Class 150
Size 2"

Available Interior and Floating Ball Material Code:

SS304 CF8 Stainless Steel: 1
SS316 CF8M Stainless Steel: 2
SS316L CF3M Stainless Steel: 3

Available Seat Material Code:

Viton: 1
EPDM: 2
NBR Buna: 3

Available Rating Class Code:

Class 150: 1
Class 300: 2
Class 600: 3

Available Connection Code:

Thread NPT: 1
Flanged End: 2

Available Size Code:

1": 100
1 1/4": 125
1 1/2": 150
2": 200
2 1/2": 250
3": 300
4": 400
6": 600
8": 800

Omega Discharge Capacity by size, Flanged End:

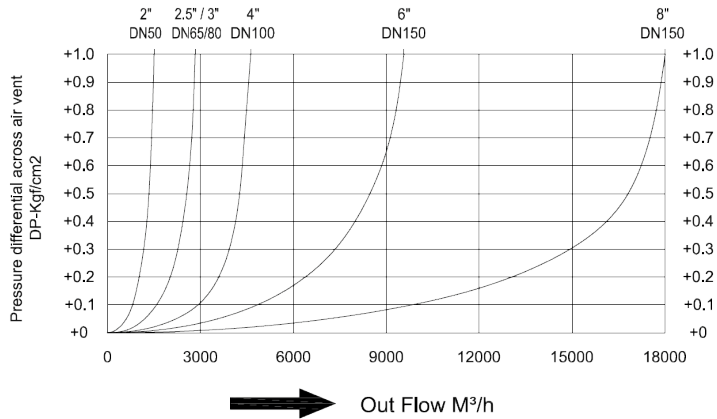

Omega Vacuum flow Charge Capacity by size, Flanged End:

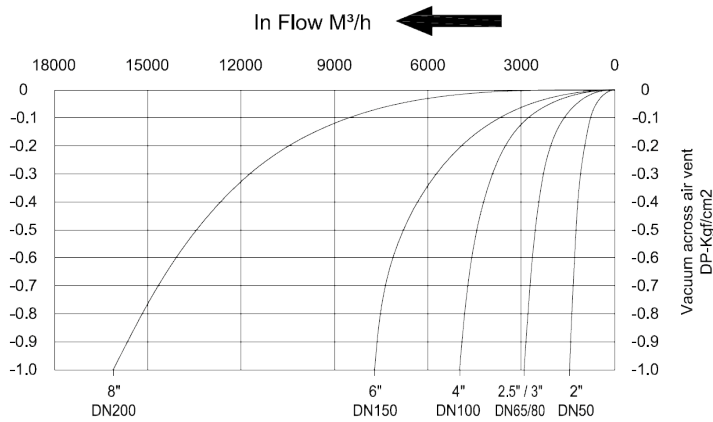

Omega Discharge Capacity by size, Thread NPT End:

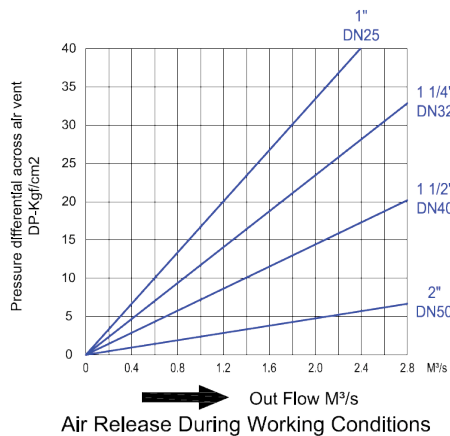

Omega Vacuum flow Charge Capacity by size, Thread NPT End:

