

Features:

- 1. Design standard: API 602
- 2. Face to face: ASME B16.10
- 3. Flange ends: ASME B16.5
- 4. Test & inspection: API 598

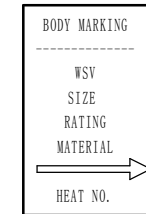

SPECIFICATION			
Pressure	ANSI Class 150LB		
Pressure test	Shell(hydrostatic)	3.0	Mpa
	Seat(hydrostatic)	2.2	
Application Temp.	-29° C ~ 325° C		

9	GB/T 16674.1-2004 Bolt	/	SS304			
8	H44W-150Lb-07	Base plate	/	B462 N08020		
7	WSV006-2008	Gasket	/	Alloy 20+Graphite		
6	H44W-150Lb-06	Lifting hook	/	B462 N08020		
5	H44W-150Lb-05	Pin	/	B462 N08020		
4	H44W-150Lb-04	Arm	/	B462 N08020		
3	H44W-150Lb-03	Disc	/	B462 N08020		
2	H44W-150Lb-02	Seat	/	B462 N08020		
1	H44W-150Lb-01	Body	/	A351 CN7M		

NO.	CODE	MAIN PARTS	QTY	MATERIAL	REMARKS
-----	------	------------	-----	----------	---------

DESCRIPTION				DRAWING		
M				2018.08.17		
SALES	DRAWN	ASSESS	AUTHORIZE	REV.	DATE	
DRW. NO.	H44W-150LB	Ref. No.				
NOTES						
WEIDOU LI VALVES CO., LTD.						

DESCRIPTION: SWING CHECK VALVE, 150LB A351 CN7M MATERIAL

WSV
Weidouli special valve

Main Dimension(mm)

Item Code	L	D	D1	D2	K	b	f	z-d
H44W-150Lb-1"	127	108	79.5	51	17	12	1.6	4-15
H44W-150Lb-1 1/2"	165	127	98.5	73	31	15	1.6	4-15

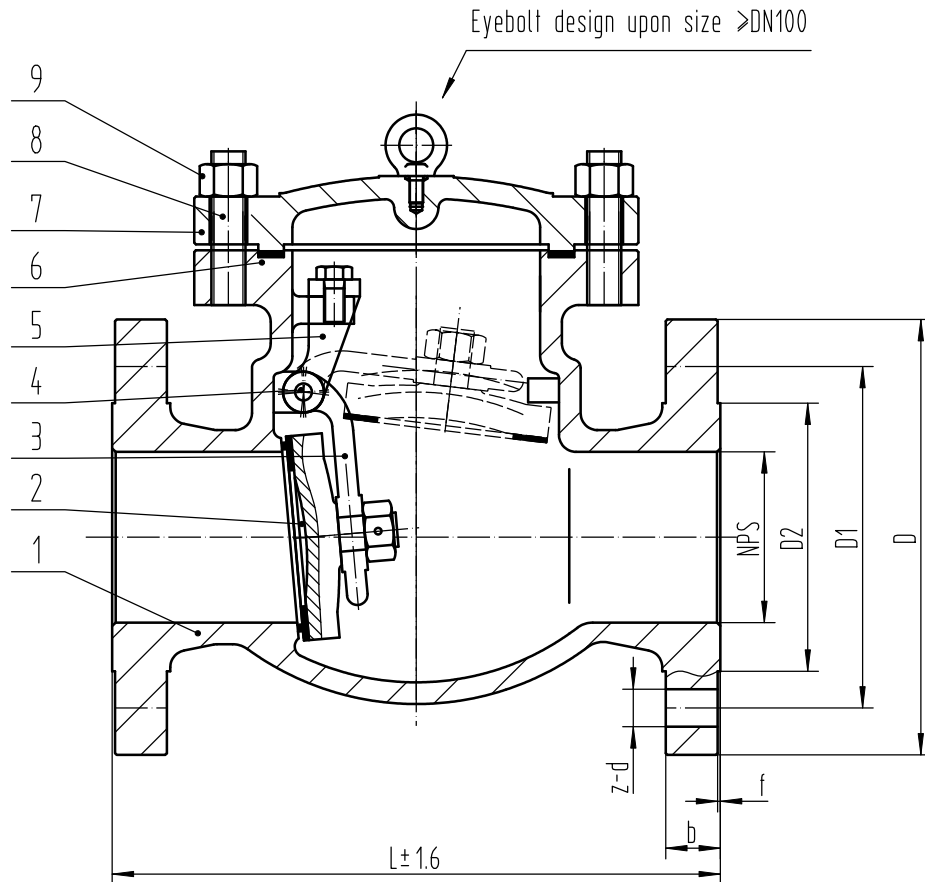

Main dimension(mm)

Item code	L	D	D1	D2	b	f	z-d
H44H-150Lb-2"	203	152	120.5	92	16	1.6	4-19
H44H-150Lb-2-1/2"	216	178	139.5	105	18	1.6	4-19
H44H-150Lb-3"	241	190	152.5	127	19	1.6	4-19
H44H-150Lb-4"	292	229	190.5	157	24	1.6	8-19
H44H-150Lb-5"	330	254	216	186	24	1.6	8-22
H44H-150Lb-6"	356	279	241.5	216	26	1.6	8-22
H44H-150Lb-8"	495	343	298.5	270	29	1.6	8-22



Features:

1. Design standard: BS 1868
2. Face to face: ASME B16.10
3. Flange ends: ASME B16.5
4. Test & inspection: API 598

SPECIFICATION			
Pressure	Class	150lb	
Pressure test	Shell (hydrostatic)	3.0	Mpa
	Seat (hydrostatic)	2.2	
Application Temp.		-29° C ~ 325° C	

9	GB/T 6170-2000	Nut	/	SS304				
8	GB/T 901-1988	Stud	/	SS304				
7	H44W-150Lb-06	Bonnet	/	A351 CN7M				
6	WSV006-2008	Gasket	/	Alloy 20+Graphite				
5	H44W-150Lb-05	Locating plate	/	A351 CN7M				
4	H44W-150Lb-04	Pin	/	B462 N08020				
3	H44W-150Lb-03	Arm	/	A351 CN7M				
2	H44W-150Lb-02	Disc	/	A351 CN7M				
1	H44W-150Lb-01	Body	/	A351 CN7M				
NO.	CODE	MAIN PART	QTY	MATERIAL	REMARKS			
					DESCRIPTION		DRAWING	
M					2018.08.17			
SALES	DRAWN	ASSESS	AUTHORIZE	REV.	DATE			
DRW. NO.	H44W-150LB		Ref. No.					
NOTES								
WEIDOU LI VALVES CO., LTD.							SWING CHECK VALVE 150LB, A351 CN7M MATERIAL  Weidouli special valve	