



Technical Specification :

1. Design and manufacture : API 602
2. Socket welding dimension : ANSI B1 20.1
4. Inspection and test : API 598

Performance Specification

Nominal pressure		800LB	
Test Pre- ssure	Shell test	21.0	MPa
	Tightness test	15.2	
	Gas-Tightness test	0.6	
Max. working temperature		425°C	
Applicable medium : Water, Oil, Gas, acid			

GATE VALVE CLASS800

SIZE	L	H	W
1/2"	73	144	100
3/4"	80	155	100
1"	100	180	125
1 1/4"	114	216	160
1 1/2"	120	234	160
2"	130	270	180

MAIN PARTS AND MATERIALS

9	Pin	A276 410	18	Nut	1035
8	Packing	Graphite	17	Name Plate	LY12
7	Bolt	A193 B7	16	Handwheel	A197
6	Bonnet	ASTM A105	15	Stem Nut	A276 410
5	Gasket	304+Graphite	14	Gasket	A240 410
4	Stem	13Cr	13	Bolt	B7
3	Wedge	13Cr	12	Nut	A194 2H
2	Seat	13Cr	11	Gland Flange	A105
1	Body	ASTM A105	10	Gland	A276 410
NO	Part name	Material	NO	Part name	Material

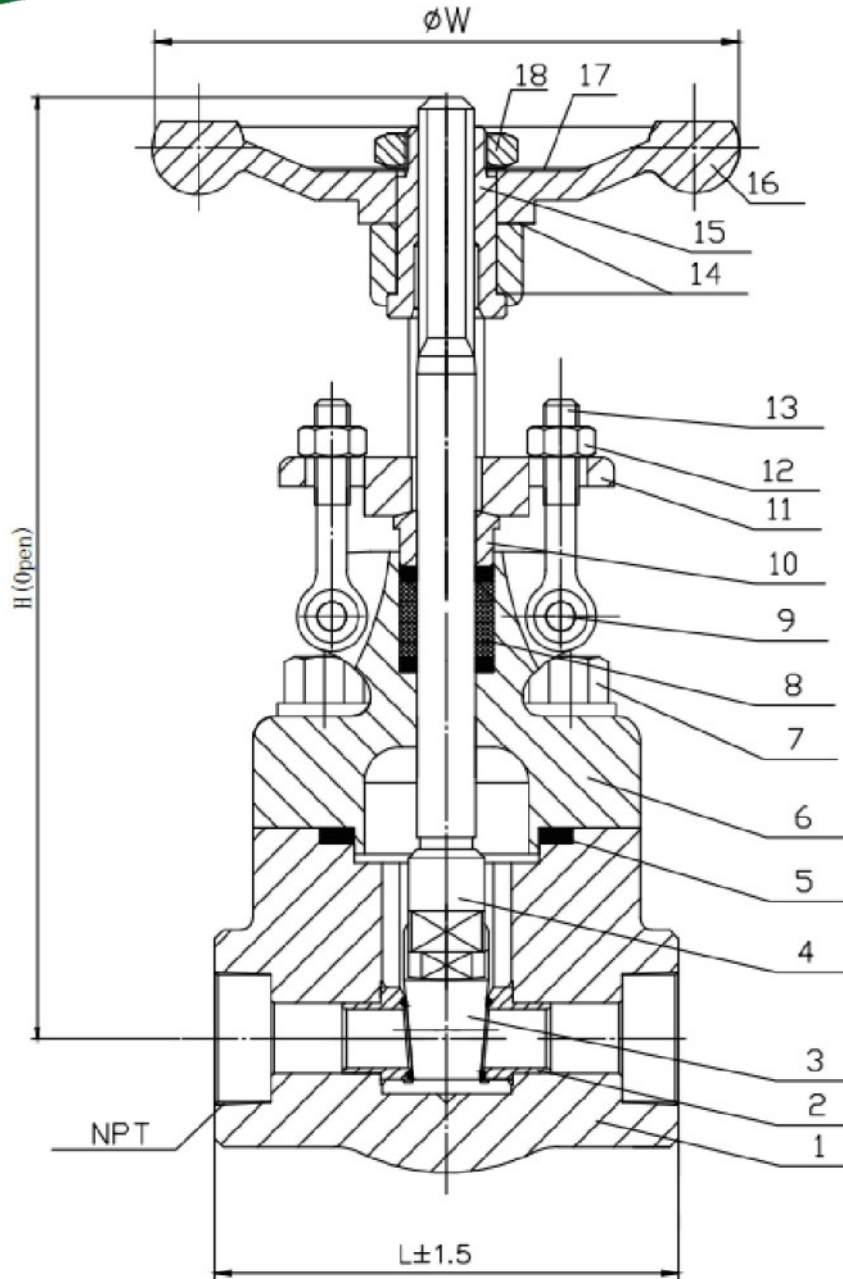

ø	管	疏踪	mm	1:1
ø637ö				
名称	800LB Gate Valve			
笔	唛	唛	唛	唛
唛	唛	唛	唛	唛
唛	唛	唛	唛	唛
+k#	唛	唛	唛	唛

