

# Series FSB 2D Direct Mount 2-Piece

## Flanged End Ball Valves

½" - 8" (DN15 - DN200)

ANSI Class 150; DIN PN16, PN40



FIRE-SAFE



ANTI-STATIC



2014/68/EU



SAFETY

# Before and After, Perfect Operation

In process industries, fire-safe equipments are often required for petroleum and flammable applications. For ideal fire-safe valves, DIE ERSTE offers Series FSB 2D Direct Mount 2-Piece Fire-safe Full Port Flanged End Ball Valve in ANSI Class 150, DIN PN16 and PN40, where maximum flow capacity and minimum pressure drops are required. Series FSB 2D conforms to API 607 5th Edition with fire-safe features, including fire-safe contact, graphite seals, and anti-static devices. The API 607 certification, which is equivalent to ISO 10497, is designed to test soft seat quarter turn valves, where valves are tested under high temperature condition (above 750°C) for certain period of time.

The fire-safe design consists of three elements: fire-safe contact, graphite seals, and anti-static devices. Fire-safe contact is a precise machined metal ring surface to fit with the valve ball after the soft ball seat has been burnt away by high temperature heat. The fire-safe contact acts as a metal seat, and together with the floating ball pushed downstream, the tight-shutoff secondary seal is formed even without the presence of soft ball seat. In the body connection where main body and end cap are connected, DIE ERSTE offers dual body seal to achieve non-leakage externally with PTFE and graphite rings. DIE ERSTE also provides anti-static device for all FSB 2D ball valves. Electrical charges can be grounded with anti-static device, to avoid potential danger.

For flange facing option, DIE ERSTE offers raised face flange for use with most general applications. For special or high pressure applications, please consult with DIE ERSTE representatives.

## (A) ISO5211 Actuator Direct-Mount

Square stem and twin ISO 5211 pattern mounting pad allow easy valve automation product installation without bracket and adaptor.

## (B) Stem Packing

The stem packing is designed to self-adjust for temperature variation and pipeline system vibration, and thus providing safe working conditions of the valve. In FSB ball valves, graphite stem packing is used to prevent stem leakage after fire.

## (C) Blowout-Proof Stem

The stem is inserted from inside the body bore. This particular design prevents the stem from shooting out when there is excess pressure in the bore caused by high temperature heat.

## (D) Anti-Static Device

All FSB ball valves are equipped with Anti-Static Device in the ball bore. This device provides a grounding path between the valve body and the ball for static electric charges built up by valve operation.

## (E) Floating Ball Design

The floating ball design, combined with soft seat, offers bubble-tight shutoff, low operating torque, and prolonged life cycle. For fire-safe purposes, the floating ball design plays important role in the formation of secondary metal-to-metal sealing property.

## (F) Fire-Safe Contact

The special designed fire-safe contact forms an alternative seal after the soft ball seat has been burnt away during fire. The new metal-to-metal seal reduces the leaking possibilities to the minimum.

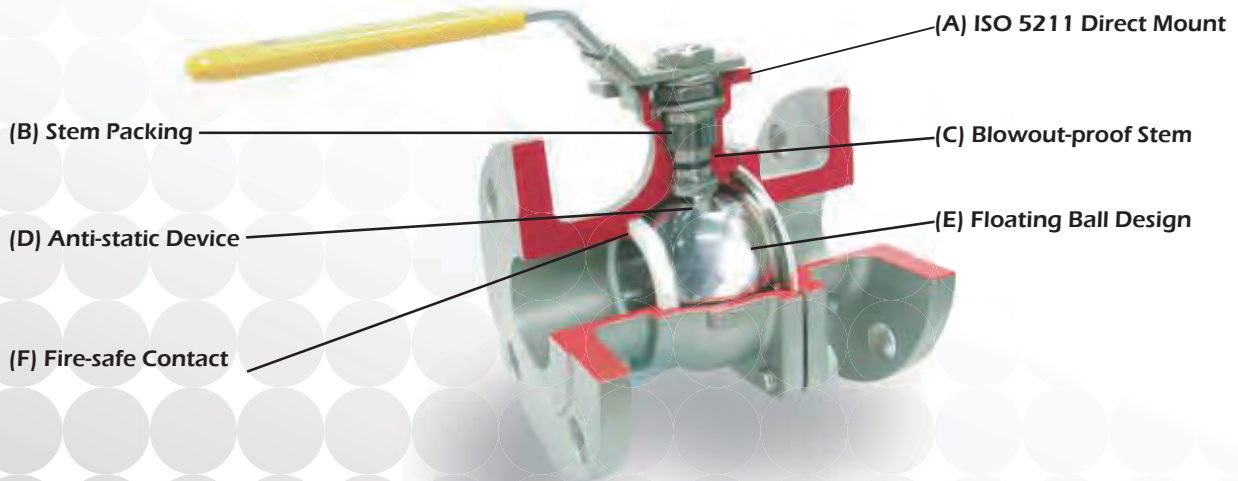

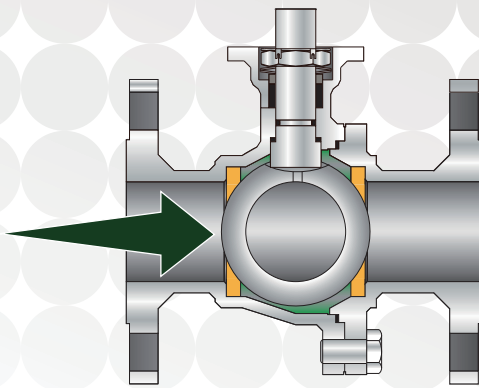

Before a fire

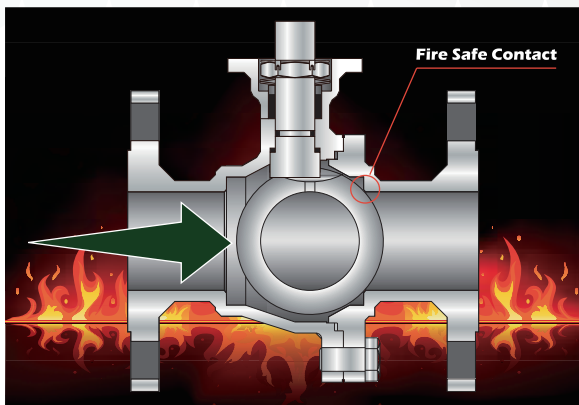

After a fire

## Fire-Safe Design

### Fire-Safe Contact

The end cap is specially designed and machined precisely to fit with the valve ball surface. During the event of fire, the soft ball seat may disintegrate in high temperature due to the nature of the material. Thus, the valve ball comes into contact with the fire-safe contact surface and forms a secondary metal-to-metal seal. The downstream flow pushes the floating ball to the side, and effectively seals the bore.

### Anti-Static Device

Anti-static device provides a grounding path to the electric charge built up from valve operations. This particular device prevents potential spark occurrence, and even fire or explosion when working with flammable fluids. Small metal balls and springs are inserted on the stem to provide the grounding path.

### Graphite Stem Seals and Packing

With the high temperature resistance property, graphite becomes the perfect material of choice for sealing parts. The graphite sealing rings are enclosed in a compartment and will not be in touch with the fluid. Therefore, regardless of the temperature and pressure, graphite seals stay immobile and continuously prevent leakage from or into the joined parts while under compression.



### Seals and Packings

#### Dual Body Seal

Dual body seal are often used in DIE ERSTE Series FSB-2D ball valves to prevent leakage. The inner body seal is made with PTFE, and the outer body seal is made with graphite.

#### Direct Mounting Pad

The dual ISO direct mounting pad allows precise and flexible mounting of actuator. Usually two sets of mounting holes are drilled for different actuator sizes. With the integrally cast top mounting platform, machined flat surface and square stem, the design ensures correct alignment of the actuator to effectively minimize the side-loading during high cycle or continuous duty applications. The well-supplied (air or electric power) actuation equipments can be removed safely and easily while the valve is under the line pressure.



### Direct Mount with Actuators

## CE Marking 0035

The whole series of ball valves is approved according to European Directive 2014/68/EU.

### Body Material:

ASTM CF8M, CF8, WCB  
DIN 1.4408, 1.4308, 1.0619

### Size Range

1/2" – 8" (DN15 ~ DN200)

### Standards

Design: ASME B16.34, BS 5351, DIN 3337  
Face to face: ASME B16.10, DIN 3202-F4  
Flange dimension: ASME B16.5, DIN 2632/2633, DIN 2634/2635  
Testing: API 607, ISO 10497, API 598, ISO 5209  
Mounting pad: ISO 5211  
Pipeline valve: API 6D  
Material: DIN EN 10204  
Marking: MSS SP-25, ISO 5209  
Others: MSS SP-72, BS 5351

### Pressure Rating:

ANSI Class 150  
DIN PN16  
DIN PN40 up to 4"  
150 psi (10 bar) with saturation steam

### Temperature Range:

- -40°F to 350°F (-40°C to 180°C) with TFM 1600 seat
- -4°F to 350°F (-20°C to 180°C) with RPTFE seat
- -4°F to 350°F (-20°C to 180°C) with PTFE seat

### End Connection:

Flanged end

### Certifications of Series FSB 2D:



**API 607 Fire Test or Soft Seated Quarter Turn Valves**



**Canadian Registration Number**



**ATEX Directive 2014/34/EU Explosive Prevention**



**Low Emission Certified  
TA-Luft 2002, Sec. 5.2.6.4  
VDI 2440 2000, Sec. 3.3.1.3**



**SIL3 Capable  
Please inquire**

### Locking Device

The locking device is ideal for applications where it is critical to keep the valve positions fixed without the risk of accidental operation. The metal piece fit accordingly to the opening on the actuator to lock on open and close position. In addition, padlock can be added with key to lock and secure the position.

### Optional Material

- Stainless Steel ASTM A351 Gr. CF3M, CF3
- Monel 400
- Low Temperature Carbon Steel ASTM A352 Gr. LCB
- Alloy 20 ASTM A351 CN7M
- Hastelloy ASTM A494 Gr. CW12MW

For more detailed information regarding different material, please contact your DIE ERSTE representatives

### Optional Material of O-Ring

- RPTFE 15%
- Viton

### Marine Application

Casting from Lloyd's or DNV approved foundry available upon request.

### Pressure and Temperature Rating

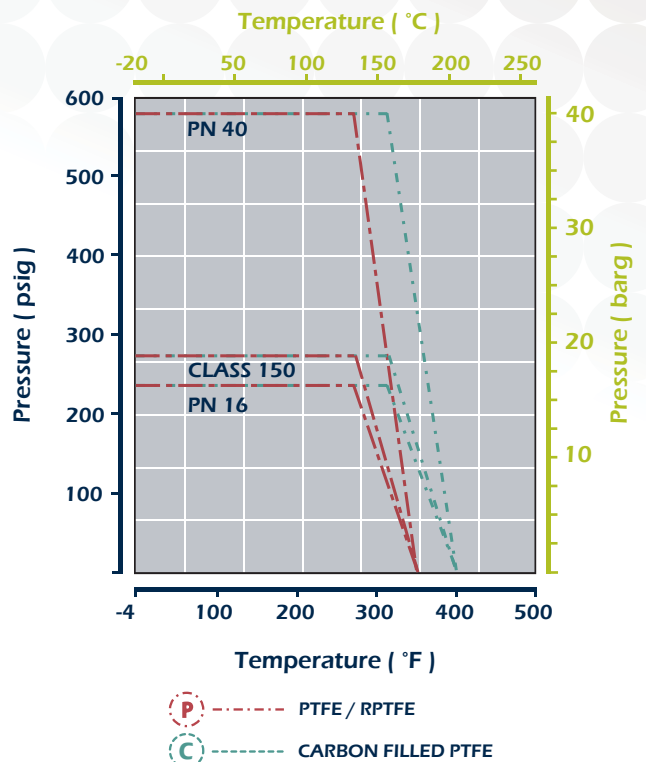

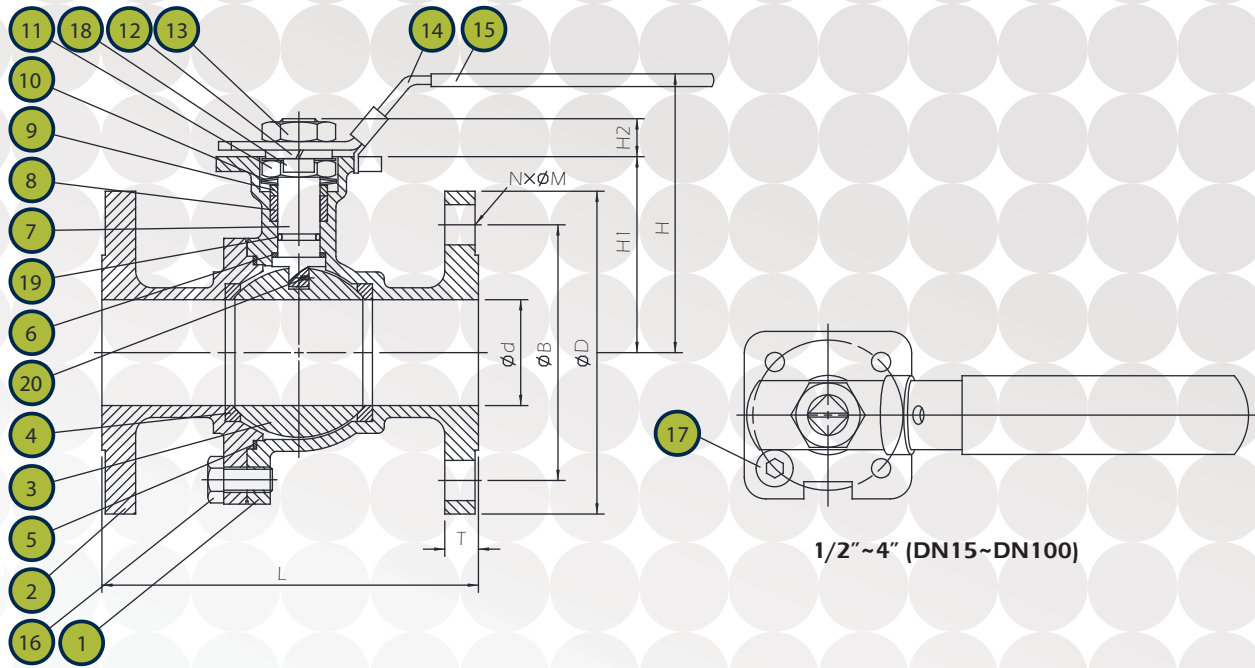

NO	PART NAME	MATERIAL
1	BODY	CF8M / WCB
2	CAP	CF8M / WCB
3	BALL	CF8M / CF8
4	BALL SEAT	PTFE / RPTFE
5	BODY SEAL	PTFE GRAPHITE
6	THRUST WASHER	PTFE GRAPHITE
7	STEM	SS316 / SS304
8	STEM PACKING	GRAPHITE
9	GLAND	SS304
10	BELLEVILLE WASHER	SS301
11	STEM NUT	SS304

NO	PART NAME	MATERIAL
12	HANDLE WASHER	SS304
13	HANDLE NUT	SS304
14	HANDLE	SS304/ ZINC PLATE STEE
15	HANDLE SLEEVE	VINYL
16	BODY BOLT	A2-70 / ISO 898-1 8.8
17	STOP PIN	SS304 / ISO 898-1 12.9
18	LOCK SADDLE	SS304
19	O-RING	VITON
20	ANTI-STATIC DEVICE	SS316

Size		Cv	Kv
Inch	DN		
1/2"	15	23	19.7
3/4"	20	45	38.6
1"	25	77	66.0
1-1/2"	40	192	165
2"	50	358	307
2-1/2"	65	611	524
3"	80	858	736
4"	100	1512	1296

The left table represents the Flow Coefficients (Cv) and Flow Factor (Kv) for DIE ERSTE Series FSB-2D ball valves. This number represents the volume of water at 60°F that will flow in US gallon per minute through a valve with a 1 lb/in<sup>2</sup> pressure drop across in the full open position. For Kv, it is the flow of water with temperature from 5°C - 30°C in cubic meters per hour (m<sup>3</sup>/h) with a pressure drop of 1 bar.

$$Cv = F \sqrt{\frac{SG}{\Delta P}}$$

The Cv value is dependent on flow rate, pressure drop, specific gravity. The larger the Cv value, the easier the fluid will flow within the valve. However, Cv value is easily affected by various factors, such as fluid type, fluid viscosity, saturated steam pressure.

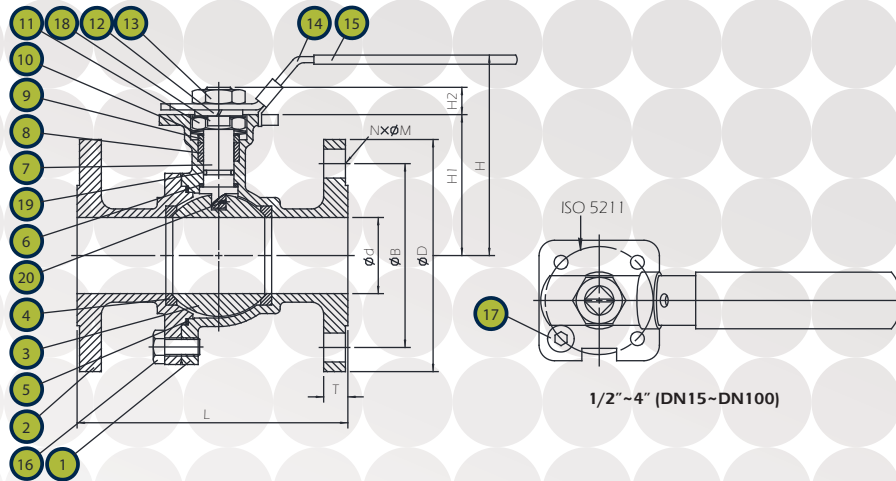

**ANSI CLASS 150 Dimensions inch/mm**

SIZE Inch DN	ød	L	T	øB	øD	M	N	W	H	H1	H2	ISO 5211	Torque N•m / lbs•in
1/2" 15	0.59 15	4.25 108	0.44 11.2	2.38 60.5	3.50 88.9	0.62 15.8	4	5.31 135	3.23 82	1.77 45	0.35 9	F03/F04	9 79.66
3/4" 20	0.79 20	4.62 117	0.44 11.2	2.75 69.9	3.88 98.6	0.62 15.8	4	5.31 135	3.46 88	1.97 50	0.35 9	F03/F04	12 106.2
1" 25	0.98 25	5.00 127	0.44 11.2	3.12 79.2	4.25 108	0.62 15.8	4	6.50 165	3.62 92	2.17 55	0.47 12	F04/F05	16 141.6
1½" 40	1.51 40	6.50 165	0.56 14.3	3.88 98.6	5.00 127	0.62 15.8	4	7.68 195	4.41 112	2.83 72	0.63 16	F05/F07	25 221.3
2" 50	1.99 50	7.00 178	0.62 15.9	4.75 120.7	6.00 152.4	0.75 19.1	4	7.68 195	5.20 132	3.62 92	0.63 16	F05/F07	38 336.3
2½" 65	2.56 65	7.50 191	0.69 17.5	5.50 139.7	7.00 177.8	0.75 19.1	4	11.81 300	5.98 152	4.13 105	0.75 19	F07/F10	60 531.0
3" 80	3.15 80	8.00 203	0.75 19.1	6.00 152.4	7.50 190.5	0.75 19.1	4	11.81 300	6.48 164	4.57 116	0.75 19	F07/F10	90 796.6
4" 100	3.94 100	9.02 229	0.94 23.9	7.50 190.5	9.00 228.6	0.75 19.1	8	13.19 335	7.64 194	5.35 136	0.87 22	F10/F12	130 1150

**PN16/40 Dimensions inch/mm**

SIZE Inch DN	ød	L	T	øB	øD	M	N	W	H	H1	H2	ISO 5211	Torque N•m / lbs•in
1/2" 15	0.59 15	4.53 115	0.63 16	2.56 65	3.74 95	0.55 14	4	5.31 135	3.46 88	1.93 49	0.35 9	F03/F04	9 79.66
3/4" 20	0.79 20	4.72 120	0.71 18	2.95 75	4.13 105	0.55 14	4	5.31 135	3.66 93	2.13 54	0.35 9	F03/F04	12 106.2
1" 25	1.00 25	4.92 125	0.71 18	3.35 85	4.53 115	0.55 14	4	6.50 165	3.86 98	2.32 59	0.47 12	F04/F05	16 141.6
1¼" 32	1.26 32	5.12 130	0.71 18	3.94 100	5.51 140	0.71 18	4	6.50 165	4.33 110	2.83 72	0.47 12	F04/F05	22 194.7
1½" 40	1.51 40	5.51 140	0.71 18	4.33 110	5.91 150	0.71 18	4	7.68 195	4.56 116	3.03 77	0.63 16	F05/F07	25 221.3
2" 50	1.97 50	5.91 150	0.79 19.9	4.92 125	6.50 165	0.71 18	4	7.68 195	4.88 124	3.35 85	0.63 16	F05/F07	38 336.3
2½" 65	2.53 64	6.69 170	0.71/0.87 18/22	5.71 145	7.28 185	0.71 18	4/8	11.81 300	5.98 152	4.13 105	0.75 19	F07/F10	60 531.0
3" 80	3.00 76	7.09 180	0.79/0.94 19.9/24	6.30 160	7.87 200	0.71 18	8	11.81 300	6.48 164	4.57 116	0.75 19	F07/F10	90 796.6
4" 100	3.94 100	7.48 190	0.79/0.94 19.9/24	7.09/7.49 180/190	8.66/9.25 220/235	0.71/0.87 18/22	8	13.19 335	7.64 194	5.43 138	0.94 24	F10/F12	130 1150

Note: Torque measured at ambient temperature with no loading; safety factor is not included.

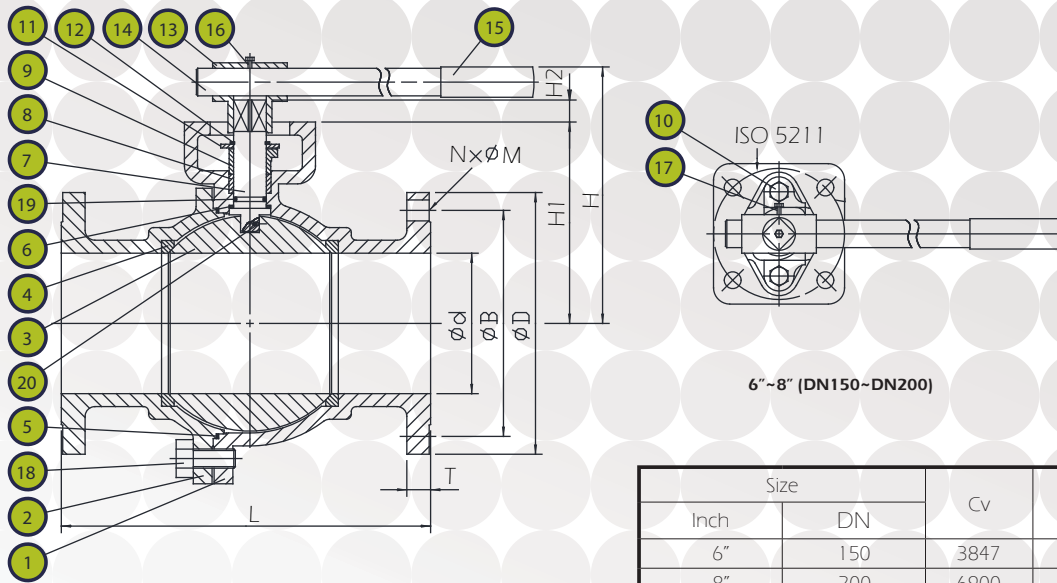

Size		Cv	Kv
Inch	DN		
6"	150	3847	3328
8"	200	6900	5969

NO	PART NAME	MATERIAL
1	BODY	CF8M / WCB
2	CAP	CF8M / WCB
3	BALL	CF8M / CF8
4	BALL SEAT	PTFE / RPTFE
5	BODY SEAL	PTFE GRAPHITE
6	THRUST WASHER	PTFE GRAPHITE
7	STEM	SS316 / SS304
8	STEM PACKING	GRAPHITE
9	GLAND	CF8 / WCB
10	GLAND BOLT	SS304 / ISO 898/1 8.8
11	LOCK SADDLE	SS304

NO	PART NAME	MATERIAL
12	HANDLE WASHER	SS304 / JIS SWP
13	HANDLE NUT	CF8 / WCB
14	HANDLE	SS304/ CARBON STEEL
15	HANDLE SLEEVE	VINYL
16	HANDLE BOLT	SS304 / ISO 898-1 8.8
17	HANDLE BOLT	SS304 / ISO 898-1 8.8
18	BODY BOLT	A2-70 / ISO 898-1 8.8
19	O-RING	VITON
20	ANTI-STATIC DEVICE	SS316

**ANSI CLASS 150 Dimensions inch/mm**

SIZE Inch DN	ød	L	T	øB	øD	M	N	W	H	H1	H2	ISO 5211	Torque N · m/ lbs · in
6" 150	5.91 150	15.51 394	1.0 25.4	9.5 241.3	10.98 279	0.87 22.2	8	22.83 580	10.94 278	8.58 218	1.10 28	F12/F14	180 1593
8" 200	7.87 200	17.99 457	1.13 28.6	11.75 298.5	13.5 343	0.87 22.2	8	37.4 950	13.98 355	10.5 267	1.46 37	F14	380 3363

**PN16/40 Dimensions inch/mm**

SIZE Inch DN	ød	L	T	øB	øD	M	N	W	H	H1	H2	ISO 5211	Torque N · m/ lbs · in
6" 150	5.91 150	13.78 350	0.94/1.10 24/28	9.45/9.84 240/250	11.22/11.81 285/300	0.91/1.02 23/26	8	22.83 580	10.94 278	8.58 218	1.10 28	F12/F14	180 1593
8" 200	7.87 200	15.75 400	0.94/1.34 24/34	11.61/12.60 295/320	13.39/14.76 340/375	0.91/1.18 23/30	12	37.4 950	13.98 355	10.5 267	1.46 37	F14	380 3363

Note: Torque measured at ambient temperature with no loading; safety factor is not included.

UHMWPE – Ultra High  
Molecular Weight Polyethylene

PCTFE

DELRIN®

## Valve Seat Selection

Please contact your sales for more properties of materials

Reinforced PTFE,

Carbon Filled

PEEK®

Seat Code	Description	Temperature Range
VIRGIN PTFE	The most common material of seat ring. With excellent chemical resistance, PTFE can be used almost in all media.	-20°C to 180°C (-4°F to 350°F)
RPTFE (15% GLASS FILLED PTFE)	Similar to PTFE, but offers higher pressure capacity while temperature is increasing. The material itself is harder than conventional PTFE. Please specify the application due to confusion with PTFE.	-20°C to 180°C (-4°F to 350°F)
CARBON FILLED PTFE	Specially used for steam and thermal oil, with low coefficient of friction. The chemical resistance is similar to PTFE and RPTFE. 15% carbon and 25% carbon are provided.	-20°C to 200°C (-4°F to 392°F)
S/S POWDER FILLED PTFE	Combined with the strength of stainless steel and lubricity of PTFE, 50% SS316 powder is added to 50% PTFE. Abrasion resistance of metal and higher pressure rating than RPTFE.	-20°C to 200°C (-4°F to 392°F)
TFM1600	TFM is a modified PTFE which reduces permeation to provide advantages for corrosive applications or those applications where PTFE is used as a barrier to protect against or contain aggressive chemicals.	-40°C to 180°C (-40°F to 350°F)
DELRIN	High pressure seat material. Delrin material is able to sustain pressure up to 5000 psig. However, it is not recommended to use in oxygen applications.	-20°C to 80°C (-4°F to 180°F)
PEEK	Highest pressure resistance. Excellent in recovery from deformation, and high degree of dimensional stability. High mechanical strength.	-20°C to 240°C (-4°F to 464°F)



# More Automation Choices

## Pneumatic Actuators

### VT Series – Rack & Pinion Type

The VT Series rack & pinion actuators are reliable quality products, which can be relied on to perform faultlessly under any difficult circumstances. For double-acting mode, the actuator is available in 11 sizes. Under the provision of common power supply (80 psi), the output torque ranges from 8.02 to 2877 Nm (71 to 25469 in-lbs). For single-active, also known as spring return type, 10 sizes are available.

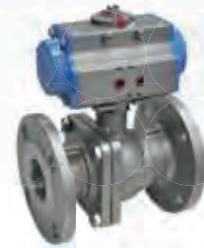

## Electric Actuators

### JS Series

The Jexme electric actuators are made in new sizes from 34.3 to 597.8 Nm (303.6 to 5290.8 in-lbs), which are generally applied for ball valves with maximum size 6", and butterfly valves with maximum size 12", and are available in on-off or modulating versions, with a choice of duty cycles. All models include standard manual override, visual position indicator, torque limiter and adjustable-position switches.



## VSII™ Namur Type Solenoid Valves for Valve Actuator

VSII™ namur type solenoid valve is specifically engineered to pilot pneumatic process valve actuators. Using enhanced materials, VSII™ has an operating temperature range from -20°C up to 50°C (-4°F up to 140°F). The most notable improvement is the patented rotary sealing plate. It features in the field conversion form 3/2 to 5/2 action without the need for tools or additional parts, and incorporates exhaust feedback to increase actuator spring life span.



## Other Fire-safe Products

FSB 35	FSB 26	FSB 23	FSB 1D	FSB 22
				
2000 psi (140 bar) DN8 - DN100	6000 psi (420 bar) DN8 - DN50	3000 psi (210 bar) DN8 - DN50	PN16/PN40 DN15 - DN100	2000 psi (140bar) DN8 - DN50



Taiwan  
5F-1, No.936,  
Sec. 4, Wen-Sin Road  
Taichung City, 406, Taiwan  
T +886(4)2231 0059  
F +886(4)2236 0236

Shanghai  
Rm. 1803-A, No.  
678, Gu-Bei Rd.,  
Shanghai, China  
T +86(21)5777 3810  
F +86(21)5777 3819

DIE ERSTE INDUSTRY CO., LTD.  
www.die-erste.com | sales@die-erste.com

Copyright © 2017 by DIE ERSTE INDUSTRY CO., LTD. CM-112/FSB 2D V4.1

Due to continuous development of the products, DIE ERSTE reserves the right to alter the dimension and information contained in the document as required. For specific performance data and proper material selection, please consult with your DIE ERSTE representatives

**Distributor:**

