



PRESSURE RESTRICTING ANGLE VALVE

WITH HYDROLATOR; FEMALE NPT INLET X FEMALE NPT OUTLET

MODEL LVPRVA



EX26977



FEATURES:

300 lb (2070 KPa) pressure tested approved valve. Heavy Duty 1-1/2" (38 mm) pressure restricting angle hose and hydrolator valve. Automatically drains and vents, safeguarding against hose deterioration. O-ring packing and red cast handle. Forgeline Bonnett and Seat Assembly. Water pressure is controlled by adjustable flow restriction. If full flow is required, the restriction may be overridden. Furnished with field setting chart. Contains lead. Not for use in water systems intended for human consumption.

- SIZE : 1 1/2" F x FNST
- 2 1/2" M x FNST
- 2 1/2" M x FYFD

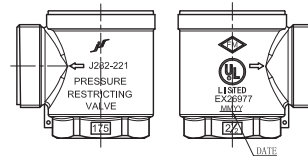
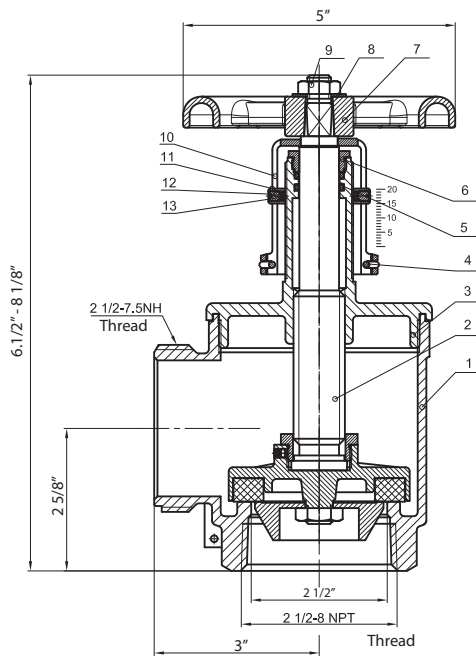

PRESSURE RESTRICTING ANGLE HOSE VALVE			
ITEM	PART	QTY	MATERIAL
1	Body	1	C37700
2	Spool Assembly	1	
3	Bonnet	1	C37700
4	Wire	1	304
5	O-Ring	2	EPDMA (A70)
6	Gland Nut	1	C37700
7	Wheel	1	ZL102
8	Washer	1	304
9	Wheel Nut	1	C37700
10	Set Numbers	1	C37700
11	Collar	1	C37700
12	Set Screw	2	304
13	Washer	1	PA6

*Contact Lansdale for UL/FM listings

PROJECT	APPROVAL STAMP
PROJECT:	<input type="checkbox"/> APPROVED
ADDRESS:	<input type="checkbox"/> APPROVED AS NOTED
ENGINEER:	<input type="checkbox"/> NOT APPROVED
SUBMITTAL DATA:	REMARKS:
NOTES 1:	
NOTES 2:	