

Main Technical Parameter		
Normal pressure	2000	PSI
Test pressure	Shell test pressure	21
	Tightness test	15.4
	Gas-Tightness test	0.6
Max working temperature	-29~+150	°C
Suitable medium: Water, oil, gas, acid, steam. etc		

NPS	φd	NPT	L	□ E×E	H	H1	H2	W	ISO 5211 Pad
1/2"	φ15	1/2"	75	9×9	68	40	9	135	F03/F04
3/4"	φ20	3/4"	80	11×11	84	51.5	11	160	F04/F05
1"	φ25	1"	90	11×11	86	58	11	160	F04/F05
1 1/4"	φ32	1 1/4"	110	14×14	104	70	15	215	F05/F07
1 1/2"	φ40	1 1/2"	120	14×14	113	75	15	215	F05/F07
2"	φ50	2"	140	14×14	124	88	15	215	F05/F07
2 1/2"	φ65	2 1/2"	185	22×22	170	115	24	360	F07/F10
3"	φ78	3"	205	22×22	182	125	24	380	F07/F10

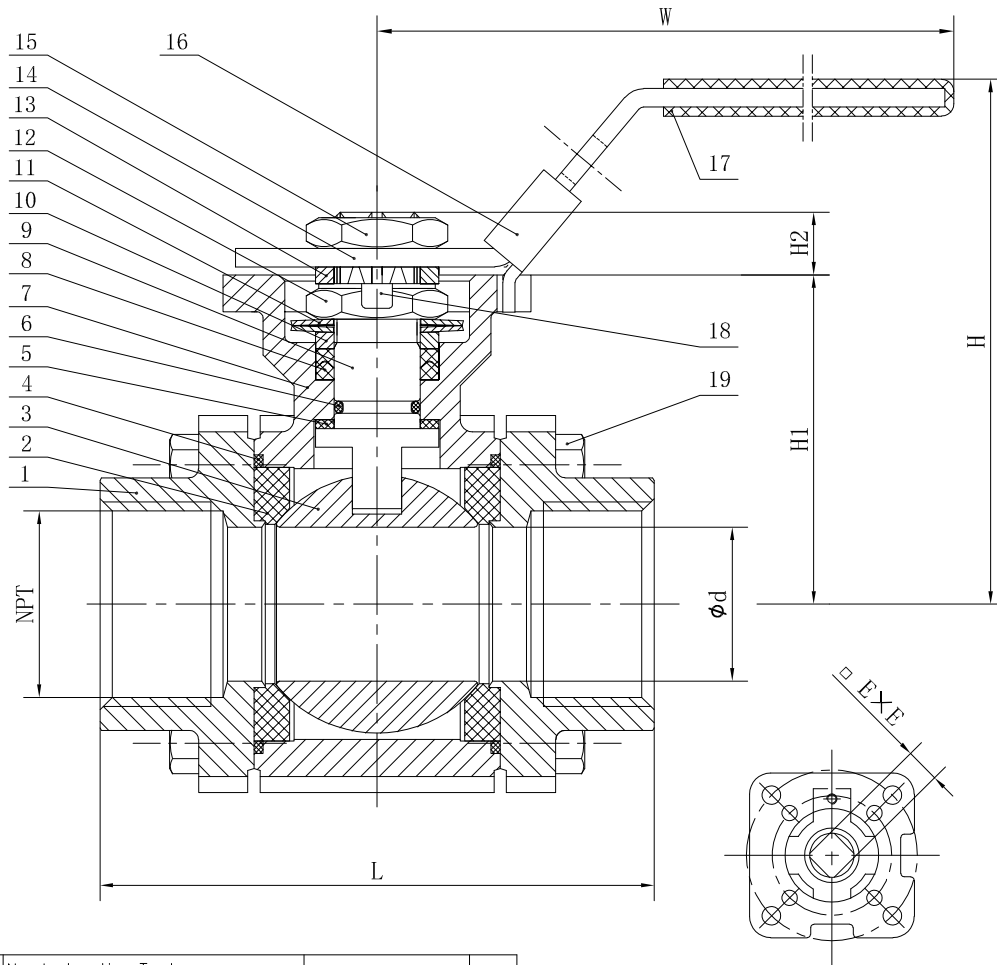

ISO 5211
MOUNTING PAD

1.	Nondestructive Test		
1.1	Pressure Test	API 598	Yes
1.2	Chemical composition certification	Mandatory	Yes
1.3	Penetrant Test	All Body Surface	Yes
1.4	Magnetic particle testing	All Body Surface	Yes

TECHNICAL SPECIFICATION

1. Basic design and manufacture according to ASME B16.34
2. Adjustable packing gland, Bottom-loaded blow-out proof
3. NPT Threaded Standard as to ASME B1.20.1
4. Inspection and tested according to API 598
5. Face-To-Face dimension standard: MFR-STD
6. Valve as per NACE MR-01-75(2002) requirement
7. Fire safe design conforms To API 607

No.	Parts name	Material	No.	Parts name	Material
1	Bonnet	ASTM A351 CF8M	12	Stem Nut	ASTM A276 304
2	Seat	RPTFE	13	Packing Gland	ASTM A276 304
3	Ball	ASTM A276 316	14	Handle	ASTM A276 304
4	Gasket	SS316+Graphite	15	Nut	ASTM A276 304
5	Stem Gasket	CPTFE	16	Locking Device	ASTM A276 304
6	O-Ring	Viton	17	Handle sleeve	Plastic
7	Body	ASTM A351 CF8M	18	Thrust Washer	ASTM A276 304
8	Packing	Graphite	19	Hexagonal bolt	ASTM A276 304
9	Stem	ASTM A276 316	20		
10	Packing Gland	ASTM A276 316	21		
11	Butterfly Spring	ASTM A276 304	22		

3PC BALL VALVE WITH
ISO 5211 MOUNTING PAD
NPT

PTV[®]
Solutions

NPS 1/2"~3"-2000WOG-NPT
SS316/SS316/RPTFE