

Main dimension (mm)						Weight (KG)	Torque N*M without Safety factor
NPS	L	Ød	NPT	H	W		
1/2"	92	Ø14	1/2"	65	135	1.85	20
3/4"	111	Ø19	3/4"	78	165	2.70	25
1"	127	Ø25	1"	90	220	4.40	35
1.1/4"	140	Ø32	1.1/4"	93	220	6.35	45
1.1/2"	152	Ø38	1.1/2"	103	255	8.72	60
2"	178	Ø49	2"	115	305	10.90	80

*Safety factor of 1.3 is recommended

1.	Nondestructive testing		
1.1	Pressure test	API 598	Yes
1.2	Chemical composition certification	Mandatory	Yes
1.3	Penetrant test	All Body Surface	Yes
1.4	Magnetic particle testing	All Body Surface	Yes

PTV[®]
Solutions

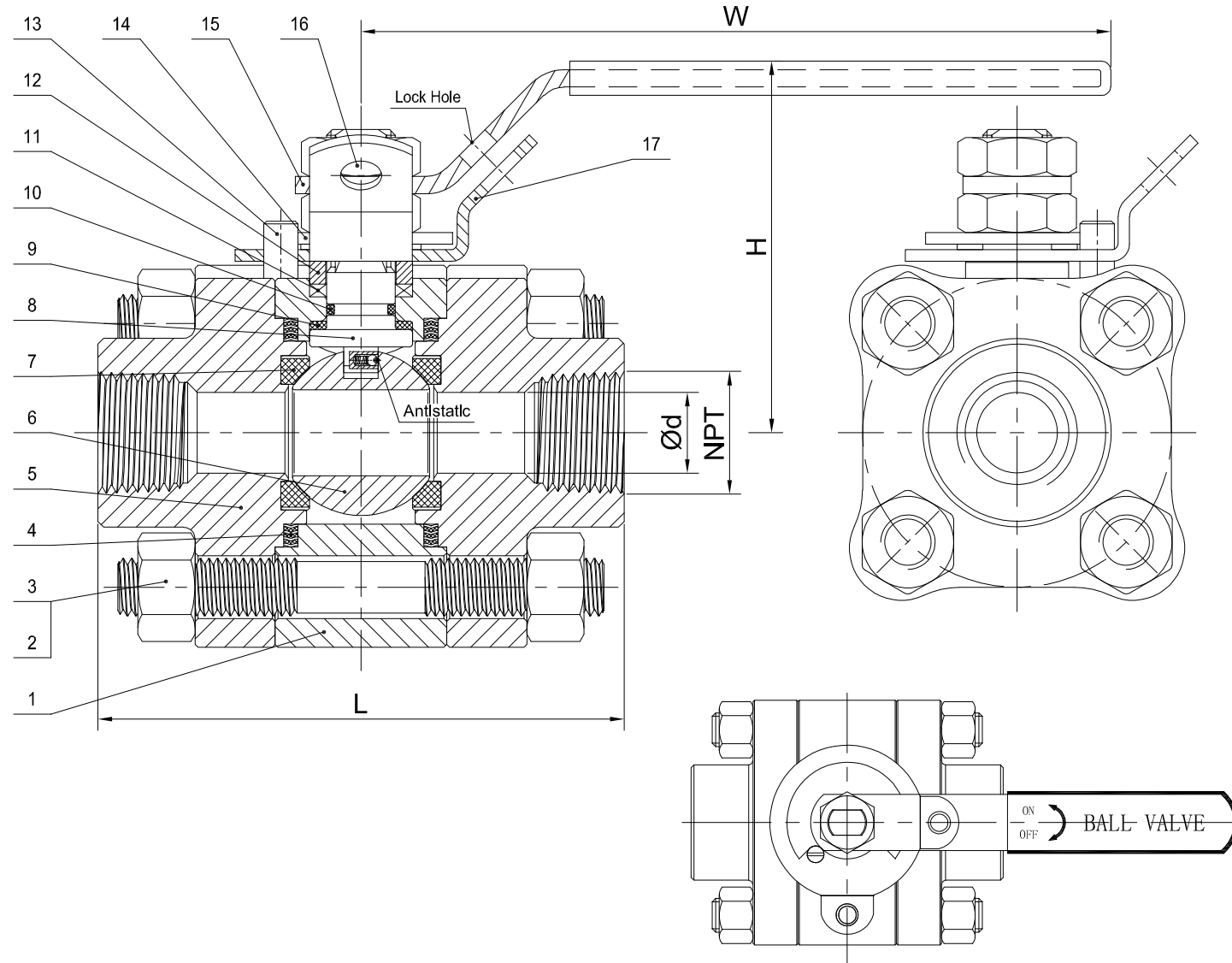

NO.	PART NAME	MATERIAL	REMARKS
1	BODY	ASTM A105	
2	STUD BOLTS	A193 GR.B7	
3	NUT	A194 GR.2H	
4	BODY GASKET	SS316+GRAPHITE	
5	BONNET	ASTM A105	
6	BALL	A182 F316	
7	SEAT RING	DEVLON	
8	STEM	A182 F316	
9	THRUST WASHER	RPTFE	
10	STEM "O" RING	VITON	
11	PACKING	GRAPHITE	
12	GLAND	A276 SS316	
13	POSITIONING PIN	STAINLESS STEEL	
14	POSITIONING PLATE	STAINLESS STEEL	
15	LEVER	SS201+PLASTIC	
16	STEM NUT	SS304	
17	LOCKING DEVICE	SS304	

SPECIFICATION REQUIRED	ASME B16.34
TYPE of VALVE	FLOATING TYPE
VALVE OPERATING	LEVER OP.
VALVE PRESSURE CLASS	3000 PSI
END CONNECTION TYPE	NPT
END to END DIMENSION	MANUFACTURER STANDARD
SCREWED END	ASME B1.20.1
TEST	API 598
FIRE SAFE TEST	API 607
APPLICABLE TEMPERATURE	-20°C ~ +120°C
APPLICABLE MEDIA	WATER.OIL.GAS.STEAM. etc

TEST PRESSURE	PRESSURE	SHELL: 30.80 MPa
		SEAT: 22.60 MPa
	PRESSURE	SEAT: 0.60 MPa

Date	REV.No.	DESIGNED
DWG.No.		REVIEWED
CLIENT		APPROVED

3PC FORGED STEEL FLOATING TYPE BALL VALVE
NPS 1/2"-2" CLASS 3000PSI A105/F316/DEVLON NPT

PTV[®]
Solutions