

Main Technical Parameter		
Normal pressure	2000	PSI
Test pressure	Shell test pressure	21
	Tightness test	15.4
	Gas-Tightness test	0.6
Max working temperature	-29~+150	°C
Suitable medium: Water, oil, gas, acid, steam. etc		

NPS	φd	L	φS	A	□ E×E	H	H1	H2	W	ISO 5211 Pad	Torque (N*M)	Weight (KG)
1/2"	φ15	78	φ21.8	9.6	9×9	68	40	9	135	F04	13.5	0.75
3/4"	φ20	81	φ27.1	12.7	9×9	84	51.5	11	160	F04	18	0.82
1"	φ25	100	φ33.8	12.7	9×9	86	58	11	160	F04	23	1.63
1 1/4"	φ32	110	φ42.6	12.7	11×11	104	70	15	215	F05	31	2.95
1 1/2"	φ40	120	φ48.7	12.7	14×14	113	75	15	215	F05/F07	41	4.05
2"	φ50	136	φ61.1	15.9	14×14	124	88	15	215	F05/F07	55	6.56
2 1/2"	φ65	185	φ74.0	18	22×22	170	115	24	360	F07/F10	76	11.68
3"	φ78	205	φ90.0	18	22×22	182	125	24	380	F07/F10	108	17.5

*Torque is without Safety factor. Safety factor of 1.3 is recommended

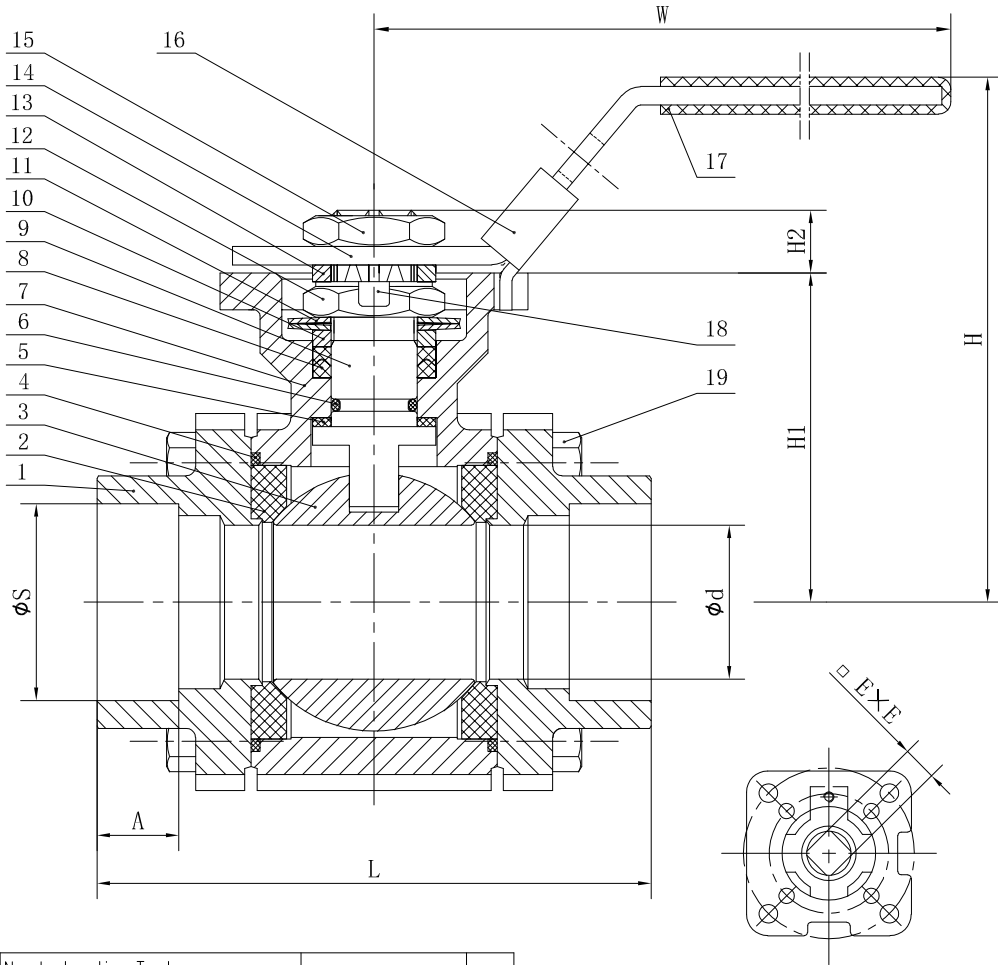

ISO 5211 MOUNTING PAD

TECHNICAL SPECIFICATION

1. Basic design and manufacture according to ASME B16.34
2. Adjustable packing gland, Bottom-loaded blow-out proof
3. Socket Welded ends complied with ASME B16.11
4. Inspection and tested according to API 598
5. Face-To-Face dimension standard: MFR-STD
6. Fire safe design conforms To API 607

No.	Parts name	Material	No.	Parts name	Material
1	Bonnet	ASTM A216 WCB	12	Stem Nut	13Cr
2	Seat	RPTFE	13	Packing Gland	ASTM A276 304
3	Ball	ASTM A276 316	14	Handle	ASTM A276 304
4	Gasket	SS316+Graphite	15	Nut	ASTM A276 304
5	Stem Gasket	CPTFE	16	Locking Device	ASTM A276 304
6	O-Ring	EPDM	17	Handle sleeve	Plastic
7	Body	ASTM A216 WCB	18	Thrust Washer	ASTM A276 304
8	Packing	Graphite	19	Hexagonal bolt	ASTM A276 304
9	Stem	ASTM A276 316	20		
10	Packing Gland	ASTM A276 304	21		
11	Butterfly Spring	ASTM A276 304	22		

3PC BALL VALVE WITH
ISO 5211 MOUNTING PAD
SW



NPS 1/2"~3"-2000WOG-SW
WCB/SS316/RPTFE

1.	Nondestructive Test		
1.1	Pressure Test	API 598	Yes
1.2	Chemical composition certification	Mandatory	Yes
1.3	Penetrant Test	All Body Surface	Yes
1.4	Magnetic particle testing	All Body Surface	Yes