

Hydro' Test Pressure

| | Kgf/cm ² | psi |
|------|---------------------|-----|
| BODY | 24.6 | 350 |
| SEAT | 15.8 | 225 |

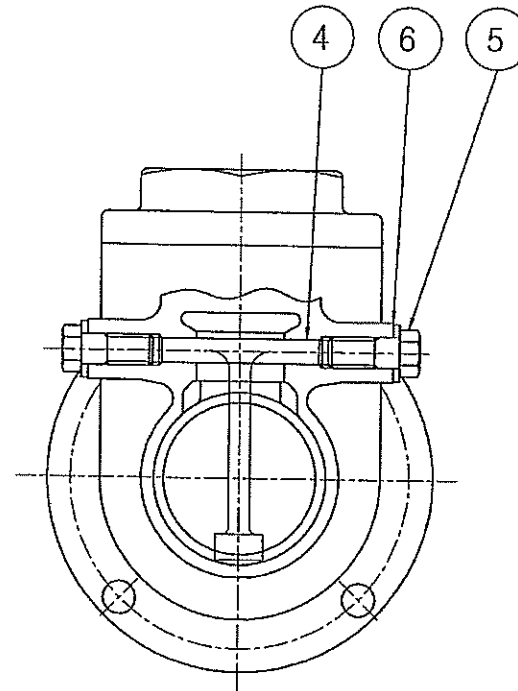
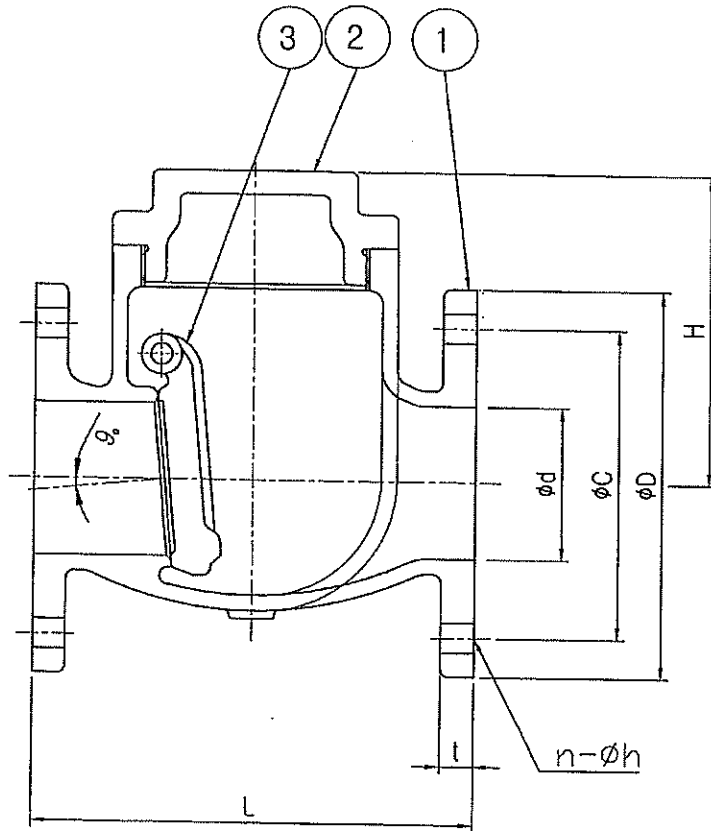

NOTE

- * Applicable Standard
- 1. Face to Face : Maker Standard
- 2. Flange Dimension : ASME B16.24
- 3. Inspection & Test : API 598

| 6 | Gasket | Non-Asbestos |
|-----|-----------|--------------|
| 5 | Plug | B124-C37700 |
| 4 | Hinge Arm | |
| 3 | Disc | B62-C83600 |
| 2 | Cover | |
| 1 | Body | |
| NO. | COMPONENT | MATERIAL |

| | | |
|-----|--------------|---|
| △ | | |
| △ | First Issued | |
| No. | ALTERNATION | S |

TITLE: BRONZE, SWING CHECK VALVE
ASME 150Lbs

| DRAWN. | CHEC. | APPRD. | DATE | 2011.03.30 | SCALE |
|--------|-------|-------------|----------|--------------------|-------|
| JHKANG | X | [Signature] | TYPE | Screw Bonnet | |
| | | | DWG. NO. | SWV-BC-150P-0.5-3B | |

OKVOK KWANG Engineering Co., I

| DIMENSION | | FLANGE ASME 150Lbs FF | | | | | | | L | H | Remark |
|-----------|------|-----------------------|-------|--------|------|----------|----|--|---|---|--------|
| SIZE | ød | øD | øC | n-øh | t | Unit: mm | | | | | |
| 1/2' | 12.7 | 90 | 60.5 | 4-15.7 | 7.9 | 111.1 | 51 | | | | |
| 3/4' | 19.1 | 100 | 69.9 | 4-15.7 | 8.6 | 112.7 | 51 | | | | |
| 1' | 25.4 | 110 | 79.2 | 4-15.7 | 9.7 | 130.2 | 59 | | | | |
| 1-1/4' | 31.8 | 115 | 88.9 | 4-15.7 | 10.4 | 141.3 | 67 | | | | |
| 1-1/2' | 38.1 | 125 | 98.6 | 4-15.7 | 11.2 | 165.1 | 76 | | | | |
| 2' | 50.8 | 150 | 120.7 | 4-19.1 | 12.7 | 177.8 | 97 | | | | |

DRAWING FOR REFERENCE

Hydro' Test Pressure

| | Kgf/cm ² | psi |
|------|---------------------|-----|
| Body | 24.6 | 350 |
| Seat | 15.8 | 225 |

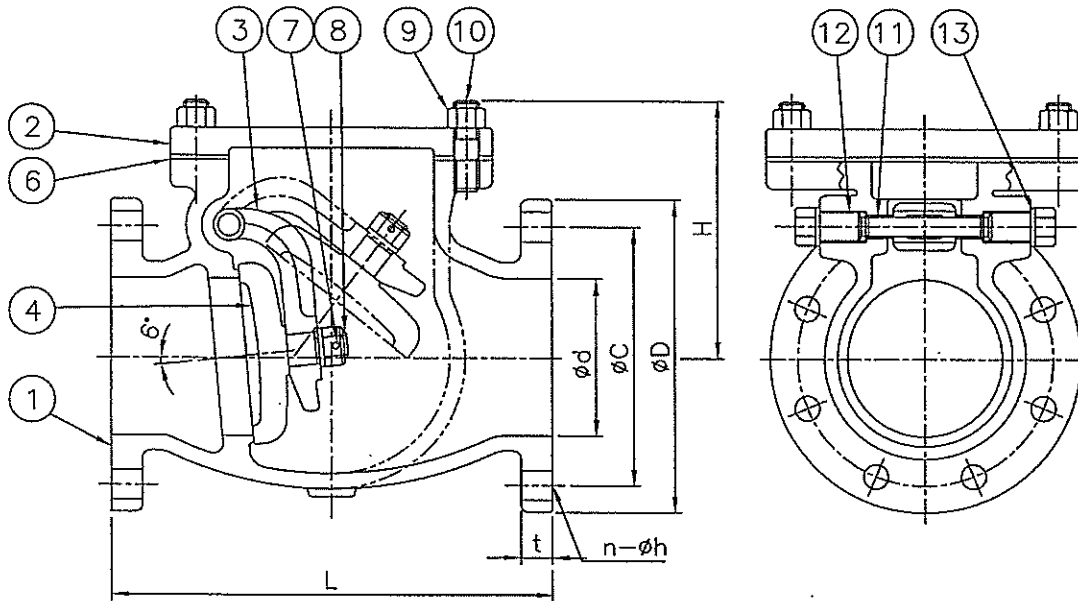

Note

- Applicable Standard
 - ANSI B16.10 : Face to Face Dimension
 - ANSI B16.24 : Flange Dimension
- Hydro Test Pressure : API 598

Dimension [Unit: mm]

| Size | ød | Flange ANSI Class 150 FF | | | | L | H | Remark |
|--------|-------|--------------------------|-------|-------|------|-----|-------|--------|
| | | øD | øC | n-øh | t | | | |
| 2" | 50.8 | 152.4 | 120.6 | 4-19 | 12.7 | 203 | 133.4 | |
| 2-1/2" | 63.5 | 177.8 | 139.7 | 4-19 | 14.3 | 216 | 146.1 | |
| 3" | 76.2 | 190.5 | 152.4 | 4-19 | 15.7 | 241 | 157.2 | |
| 4" | 101.6 | 228.6 | 190.5 | 8-19 | 17.5 | 292 | 177.8 | |
| 5" | 127.0 | 254.0 | 215.9 | 8-22 | 19.1 | 330 | 198.4 | |
| 6" | 152.4 | 279.4 | 241.3 | 8-22 | 20.6 | 356 | 209.6 | |
| 8" | 203.2 | 342.9 | 298.4 | 8-22 | 23.8 | 495 | 258.8 | |
| 10" | 254.0 | 406.4 | 361.9 | 12-25 | 25.4 | 622 | 306.4 | |
| 12" | 304.8 | 482.6 | 431.8 | 12-25 | 27.0 | 698 | 317.5 | |

| 13 | Gasket | PTFE | |
|-----|-----------------|--------------|--------|
| 12 | Side Plug | ASTM B16 | |
| 11 | Hinge Pin | | |
| 10 | Cover Stud Bolt | ASTM A193-B8 | |
| 9 | Cover Nut | ASTM A194-8 | |
| 8 | Disc Nut | ASTM B16 | |
| 7 | Cotter Pin | BRASS | |
| 6 | Gasket | Non-Asbestos | |
| 4 | Disc | | |
| 3 | Hinge Arm | | |
| 2 | Cover | ASTM B62 | |
| 1 | Body | | |
| No. | Component | Material | Remark |

| ▲ | | | |
|-----------------------------------|---------------------|---------------------------|--------|
| ▲ | | | |
| ▲ | | | |
| No. | Alternation | | Date |
| TITLE | | Bronze, Swing Check Valve | |
| | | ANSI Class 150 | |
| Date | Q'ty | Scale | Size |
| 2007. 10. 26 | | N/S | 2"~12" |
| Type | Bolted Bonnet | | |
| Material | ASTM B62 | | |
| DWG No. | SCVB-BC-150PF-2~12B | | |
| APP | CHK | DES | DWG |
| OKW OK KWANG Engineering Co., Ltd | | | |